



Fieldbus power supply for PROFIBUS PA and transparent segment coupling to PROFIBUS DP

- Two PA segments for a maximum of 62 instruments
- High-Power Trunk concept for maximum devices and long cable runs
- Motherboard design for simplified installation/wiring/maintenance
- High efficiency, low heat dissipation for highest packing density and long service life
- Module exchange without tools while the system is energized

Function

The compact PROFIBUS Power Hub is a motherboard-based segment coupler for installations with one or two PROFIBUS PA segments. It transparently couples PA segments to a PROFIBUS DP line and supplies power to PROFIBUS PA field devices. All PA slaves appear as if they are connected to the DP network and are configured that way with the original configuration software of the DP Master or control system. The compact PROFIBUS Power Hub itself is configuration free.

All electronic modules are plugged into a motherboard. Quick exchange of modules is possible without tools. Power Supply Modules feature low heat dissipation. This and the consistent use of passive components resulting in good signal quality and a very long service life.

The Power Hub feeds the High-Power Trunk for maximum cable lengths and highest number of field instruments in any explosion hazardous area: High energy level on the trunk line is limited at each spur connection via smart FieldBarriers or Segment Protectors. Field devices can be installed in the hazardous area and maintained while the system is energized.

Connection

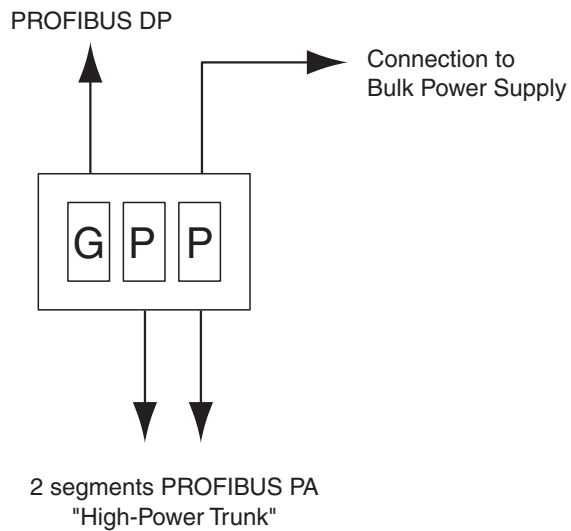

G: Gateway
P: Power Supply Module

Composition



Release date 2009-04-24 14:53 Date of issue 2009-04-24 199493-0007_ENG.xml

Supply	
Rated voltage	19.2 ... 35 V DC
Rated current	1.46 ... 0.77 A
Power loss	typ. 6.7 W
Fieldbus interface	
Number of segments	2
Rated voltage	25 ... 28 V
Rated current	360 ... 10 mA
Short-circuit current	typ. 400 mA
PROFIBUS DP	
Connection	Sub-D socket, 9-pin
Protocol	PROFIBUS DP/DP V1
Terminating resistor	100 Ω integrated
Indicators/operating means	
LED ERR	red flashing: overload error at output
LED Seg 1...2	red 2 Hz flashing: PA error, red and LED DP/ERR red: MAU error
LED PWR	Power LED: green, if $U_{out} > 25$ V
LED DP/ERR	red 2 Hz flashing: DP error ; red: Hardware error
Electrical isolation	
CH/PROFIBUS DP	functional insulation acc. to IEC 62103, rated insulation voltage 50 V _{rms}
PROFIBUS DP/Supply	functional insulation acc. to IEC 62103, rated insulation voltage 50 V _{rms}
CH/CH	functional insulation acc. to IEC 62103, rated insulation voltage 50 V _{rms}
All circuits/FE	functional insulation acc. to IEC 62103, rated insulation voltage 50 V _{rms}
Fieldbus segment/Supply	functional insulation acc. to IEC 62103, rated insulation voltage 50 V _{rms}
Directive conformity	
Electromagnetic compatibility	
Directive 2004/108/EC	EN 61326-1:2006
Low voltage	
Directive 73/23/EEC	EN 50178 (identical to EN 62103)
Standard conformity	
Electrical isolation	IEC 62103
Electromagnetic compatibility	NE 21
Protection degree	IEC 60529
Fieldbus standard	IEC 61158-2
Shock resistance	EN 60068-2-27
Vibration resistance	EN 60068-2-6
Ambient conditions	
Ambient temperature	-40 ... 60 °C (233 ... 333 K)
Storage temperature	-40 ... 85 °C (233 ... 358 K)
Relative humidity	< 95 % non-condensing
Shock resistance	15 g 11 ms
Vibration resistance	1 g , 10 ... 150 Hz
Mechanical specifications	
Housing material	Polycarbonate
Housing width	see dimensions
Height of housing	see dimensions
Housing depth	see dimensions
Protection degree	IP20
Mass	approx. 0.9 kg
Mounting	DIN rail, system M36

Release date 2009-04-24 14:53 Date of issue 2009-04-24 199493-0007_ENG.xml

Dimensions

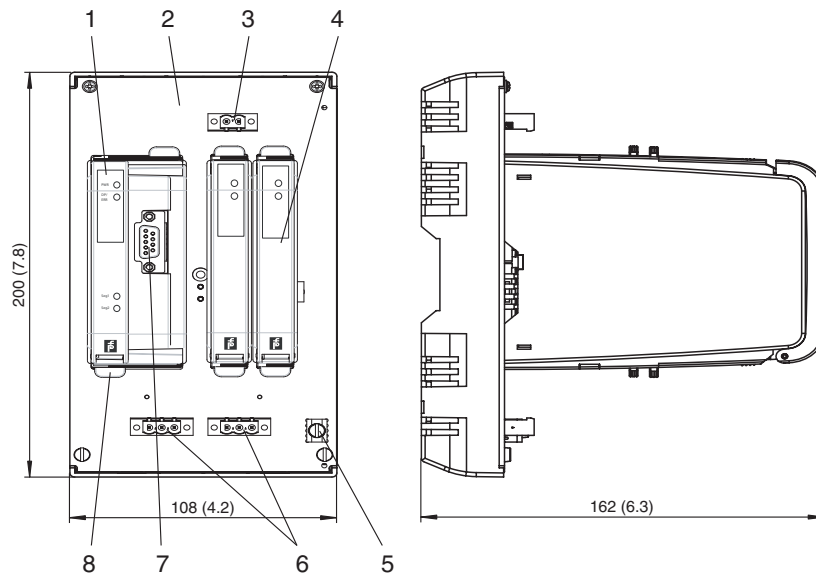

All dimensions in millimeters and inches (values in brackets) and without tolerance indication.

Description:

- 1 PROFIBUS DP/PA Gateway HD2-GTB-2PA
- 2 Motherboard MBCB-FB-GT
- 3 Power supply connection
- 4 Power supply module HD2-FBPS-1.25.360
- 5 Ground connection clamp
- 6 PA-Trunk connection
- 7 PROFIBUS DP connection
- 8 Quick-Lok bar

Scope of delivery:

- 1 x HD2-GTB-2PA
- 1 x MBCB-FB-GT
- 2 x HD2-FBPS-1.25.360